

FRONT

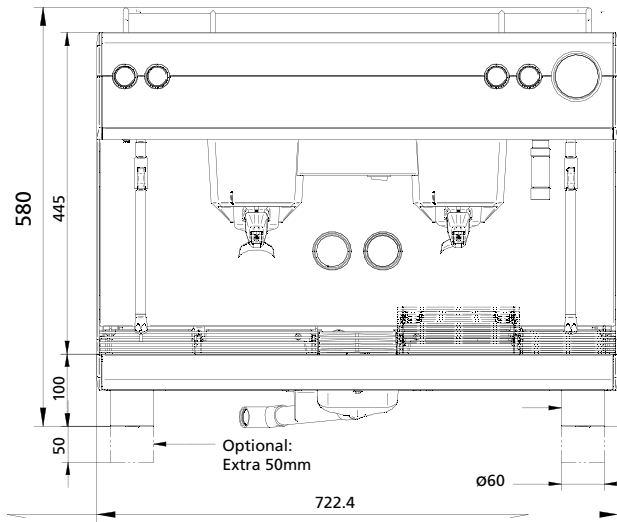

SIDE

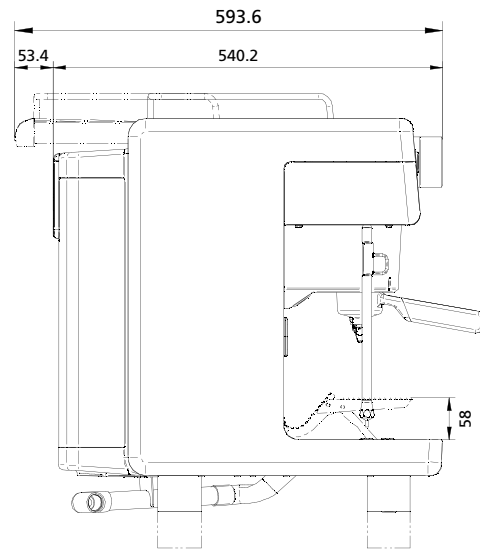

TOP

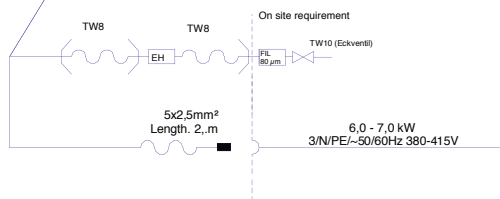
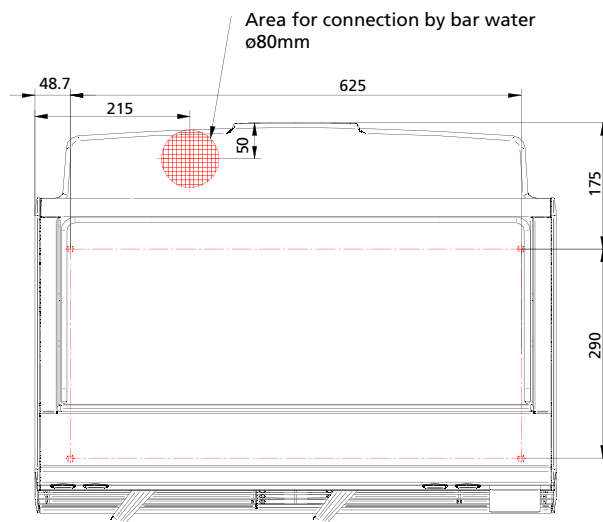
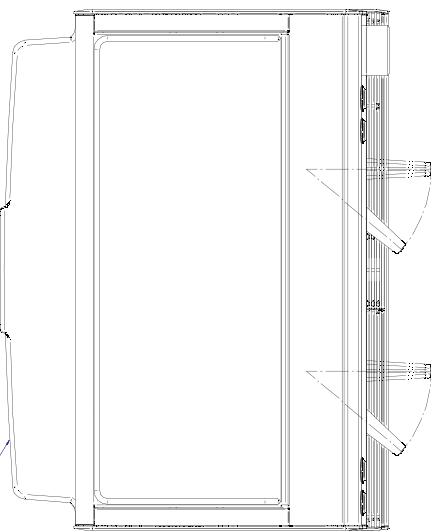

SPECIFICATIONS

Nominal power rating	6.0 - 7.0 kW
Max. hourly output*	Up to 240 cups
Coffee bean hopper(s)	each approx 550 g
Mains power connection	230 V
Dimensions (width / height / depth)	723 / 580 / 540 mm (600 with open cup storage)
Empty weight, depending on fittings	Approx. 80 kg
Continuous sound pressure level (LpA)**	< 70 dB (A)
Power Within	1m, 3 phase, 20 amp
Waste Within	1m, tongue dish
Water with Tap Within	1m, 3/8 Male Fitting (1/2 OK)

VISUAL



* Depending on the power supply and recipe settings

** The A-rated sound pressure level Lp(a) (slow) and Lp(a) (impulse) at the workplace of the staff using the machine is less than 70 dB (A) in every mode. From 5° dKH (carbonate hardness), a WMF water filter must be used. All technical changes, typographical mistakes and errors reserved for the entire contents.